

# Trail and Villager Rack

ITEM NO.	PART NUMBER	DESCRIPTION	QTY.
1	RACKTIME 20" RACK		1
2	RACK STAY	Cut to length, 8-1/2" recommended	2
3	1" TUBE CLAMPS		2
4	M5x16 SHCS	M5 SOCKET HEAD SCREW, 16mm LONG	4
5	M5 WASHER		4
6	M5 NYLOCK NUT		2

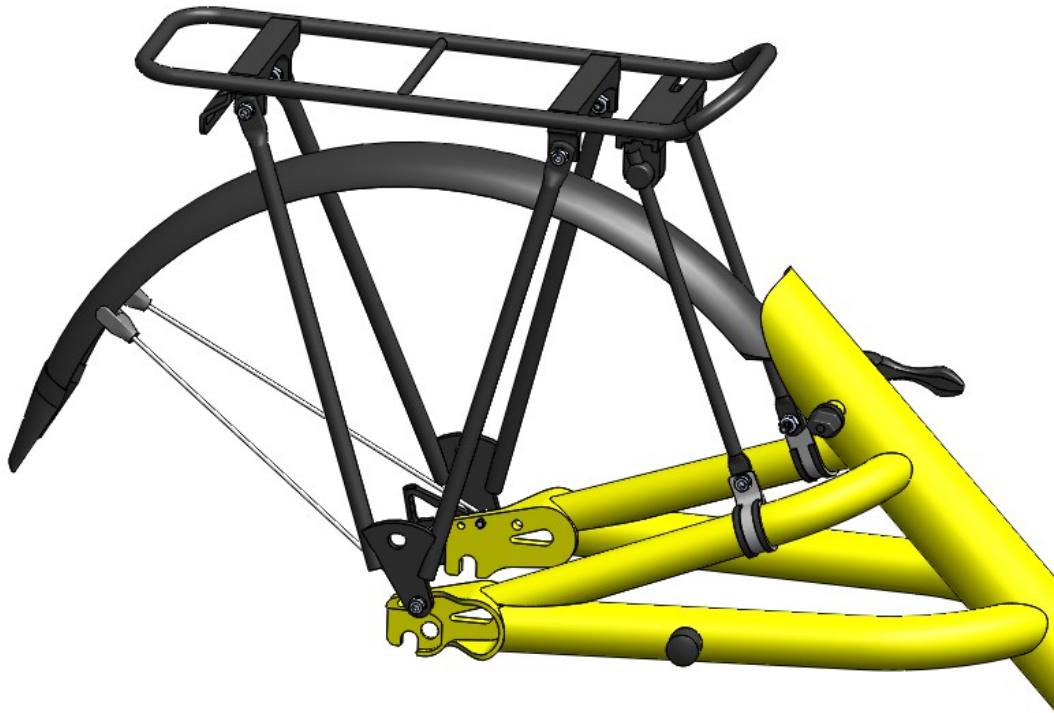

Assembly at drop outs, same both sides

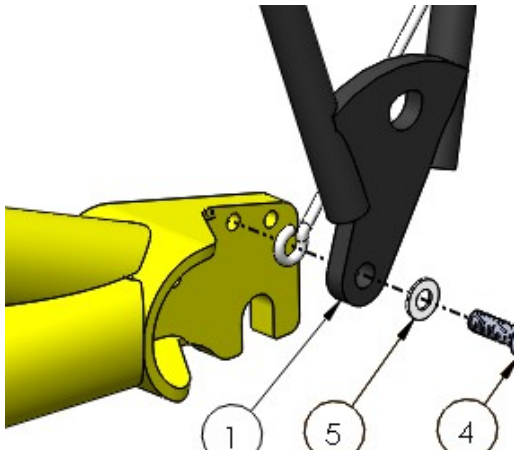

Tube Clamp Assembly

